

Does this object have two tines or three?

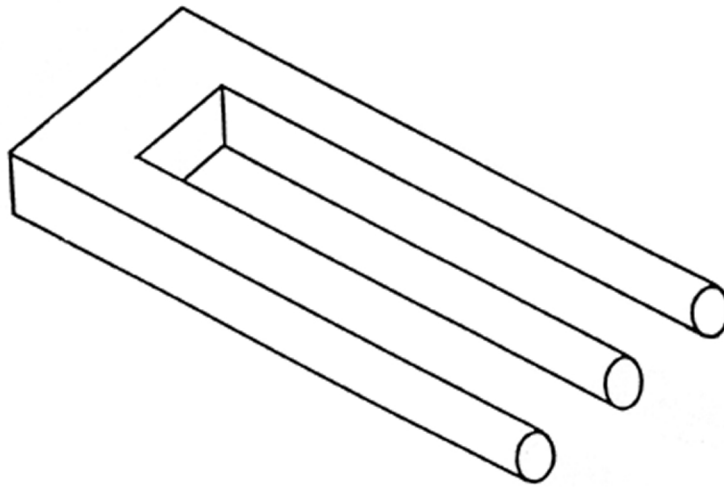

The answer is "yes." Optical illusions appear as paradoxes. How can one thing be two things? Yet that's precisely what you are: at the same time a sinner and a saint. Your dual nature has a profound effect on how you conduct your life.

STORY:

"You Are a Pneumatikon"

A what? Is this a new kind of transforming character in a video game?

No. You are alive, and that's part of it.

But just being alive does not mean you have a living relationship with God. Being alive sets up a relationship only with the natural world.

An unspiritual person does not accept the things of the Spirit of God, says the Apostle Paul (1 Corinthians 2:14). He thinks they are foolish, and he cannot know them because one must have the Spirit to judge them correctly.

Later on, Paul uses a Greek word that identifies this spiritual person: pneumatikon. (Pronounce it: "new-ma-ti-kon", the "p" is silent.)

Take a Greek lesson: pneu- means "air." pneu+ma = pneuma which means "air in motion" or "wind."

Remember how (in Acts 2:2,4) "A sound like a violent blast of wind filled the house...and they were filled with the Holy Spirit." Pneuma is also used in Scripture to mean "Spirit." So pneumatikon means "Spirit-led one."

The “unspiritual person” Paul refers to is a psychikon. This Greek word means “physically-driven.” Such a person has life, but no spirit component.

You are a pneumatikon when your life is driven by the power of God's Holy Spirit, through baptism, the Lord's Supper and Scripture. You now:

- Are doubly-alive, physically and spiritually, with a new dimension of living turned on (1 John 5:1; Romans 8:1-17)
- Have the ability to be independent and spontaneous (Acts 17:28)
- Are truly free (1 Corinthians 2:15)
- Have power to stand against Satan and the world (1 John 5:4-5)
- Can discern the underlying meaning of things (Philippians 1:9-11 and 1 Corinthians 2:14)

Spirit-powered people act in Spirit-generated ways that are able to touch both the spiritual and physical in others.

You are both physical and spiritual. As one who lives the StewardLife, make the best of both.

STORY:

“Live Skin”

Sam was a disabled veteran. He had lost most of both legs in World War II, but was able to walk with the aid of some new, modern prosthetics.

Sam bought a new suit a week ago. He walked into the men's store, picked out the suit he wanted and then went in the back to try it on so the tailor could mark it for alterations.

As the tailor was marking the trouser cuffs he reached under the cuff to insert a pin. The tailor's hand brushed against Sam's artificial leg. Sam heard the tailor let out a little gasp.

“Is everything OK?” Sam asked the tailor.

“No problem marking the suit,” the tailor replied, “but I had no idea you had artificial legs.”

The tailor had expected to feel warmth as he brushed Sam's ankle, but instead touched cold.

"I've become so accustomed to feeling the warmth of live skin that I was taken by surprise when I touched your leg," the tailor said. "I know when I'm touching live skin."

How do you know when you are around a person who is spiritually alive? What's different from the person who just has physical life?

EXERCISE:

"A One-Dimensional Steward?"

At the Indy 500, car 57 pulls into pit row and stops in front of the crew. They spring to work and fill the car with fuel and send the driver on his way. Later in the race they again fill the car with fuel. A third time, the car pulls in and fuel is added.

What's wrong with this picture?

With this kind of service, in time the car would malfunction, or, worse yet, crash. Pit crews know that tires must be replaced, spoilers adjusted, windows cleaned and the driver given liquids to prevent dehydration.

A one-dimensional steward focuses all energy on only one aspect of what God gives to manage. Are you only managing time? Or ecology? Or using one spiritual gift?

As you go through this week, practice viewing your life as a continuum, not a point; multidimensional, not linear. Like light from the sun, God's grace reaches out in all directions. Keep the eyes of your heart open to see God's blessings in your life at every turn. Let His grace illuminate and highlight all His gifts in your life--even the hidden ones--so they can be managed.

STEWARDSHIP PRINCIPLES--PRINCIPLE THREE

God's stewards are saints and sinners. God's stewards rejoice in and live out what He has declared them to be through the cross. At the same time His stewards recognize that they are sinners who fight sin and its consequences every day. See Ephesians 4:22-24; Colossians 3:5-17; Romans 7:21-25; 1 John 3:1-2; 1 Peter 2:9-10. We recognize that the potential for great good or evil lies in how stewardship is communicated, and in properly distinguishing between Law applied to the psychikon and Gospel applied to the pneumatikon. We do not appeal to selfish interests in matters of the stewardship life, for only God's steward can live the steward's life.

The resources on this web site are
© Board for Congregational Services, The Lutheran Church--Missouri Synod.
Permission is granted to copy and reproduce for personal and local use
when copyright notice below is included.
All other reproduction and publication rights are reserved.

"© Board for Congregational Services, The Lutheran Church--Missouri Synod.
Used by permission."

StewardLife® brand is a registered trademark of
The Lutheran Church--Missouri Synod for stewardship resources.